

SUNLITE®

Multiwall Polycarbonate Sheet

Technical Guide



www.palram.com

Contents

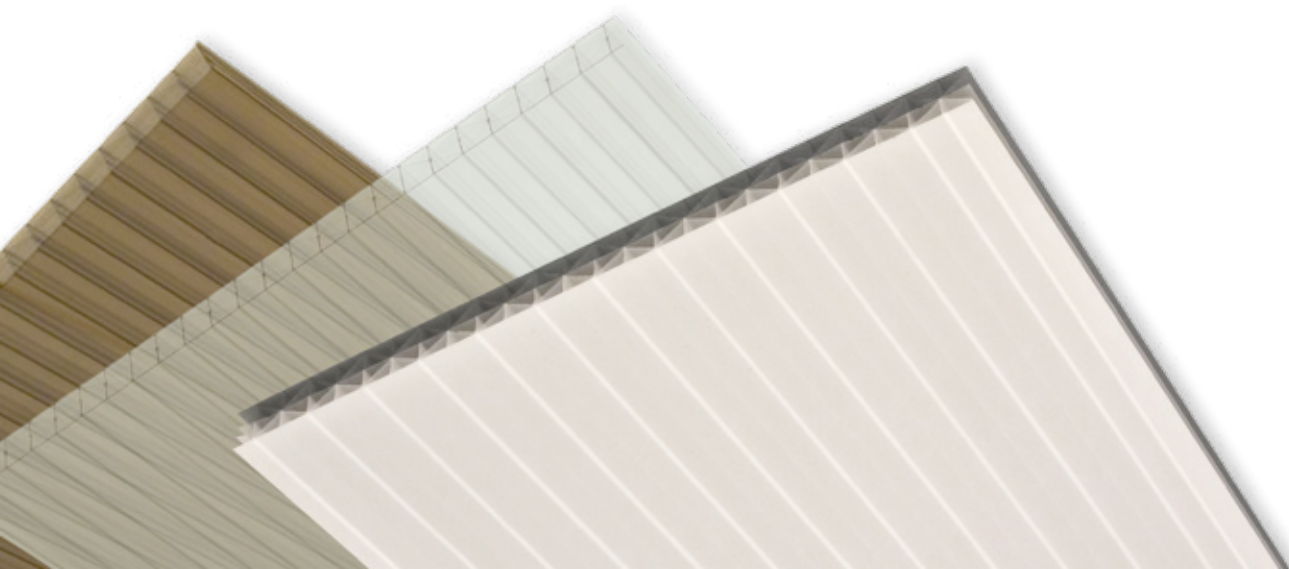

Chapter	Page
Introduction	2
Standard dimensions	2
Colors & light transmissions	2
Typical physical properties	2
Flammability	2
Chemical resistance, compatible sealants and adhesives	3
Arching radius	3
Wind and snow load calculation	4
Spacing and load calculations	4
Positioning of clamping profiles and fastener location	13
Preparation for glazing	14
Preparations prior to installation	15
Glazing profiles and fastening screws	15
Handling and storage	16
Cutting	16
Drilling	17
Sealing and bonding	17
Accessories	17
General recommendations for working with sunlite sheets	18



Introduction

This manual provides basic guidelines for selecting, handling and installing SUNLITE sheets. Due to their hollow core, preliminary preparation and additional care are required before the actual installation. Please note these guidelines before starting and follow them carefully.

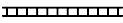
Standard Dimensions

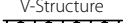
Structure	Thickness mm	Area Weight Kg/m ²	U-Value W/m ² °K	Width (mm)															
				980	1050	1200	1220	1250	1600	1800	1830	2085	2090	2095	2100				
 Twin Wall	4	0.8	3.8	✓	✓	✓	✓					✓				✓			
	4.5	1.0	3.7	✓	✓	✓	✓					✓					✓		
	6	1.3	3.5	✓	✓	✓	✓					✓					✓		
	8	1.5	3.3	✓	✓	✓	✓					✓					✓		
 Triple Wall	10	1.7	3.0	✓	✓	✓	✓					✓					✓		
	8	1.7	2.9									✓						✓	
	10	2.0	2.7									✓						✓	
	16	2.7	2.3	✓	✓	✓	✓	✓	✓	✓	✓	✓						✓	
 X-Lite	16	2.6	2.1	✓	✓			✓	✓	✓	✓							✓	
	25	3.4	1.7	✓	✓			✓	✓	✓	✓								✓
	32	3.7	1.6	✓	✓			✓	✓	✓	✓								✓
	35	3.9	1.5	✓	✓				✓	✓	✓								✓
	40	4.1	1.4																✓
 V-Structure	20	2.8	1.85											✓					
	25	3.4	1.6													✓			
	32	3.6	1.6																
	35	3.6	1.45																✓
	40	4.0	1.35																✓

Colors and Light Transmissions*

Structure	Standard Colors						Multi-Layered		Solar Smart™ Selective Solar Control Technology					
	Clear	Bronze	White Opal	White Diffuser	Green**	Blue**	Bronze/Opal	Solar Guard (Solar Control/Opal)	Solar Metallic Reflective		Infra-Red Reflective		Selective See Through	
									Solar Ice	Solar Control*	CL	SLT	Smart Green	
Twin wall 4mm	82%	35%	30%		35%	30%				30%				
Twin wall 4.5mm	82%	35%	30%		35%	30%				30%				
Twin wall 6mm	80%	35%	20%		35%	30%				30%				
Twin wall 8mm	80%	35%	35%		35%	30%				25%	45%/34%	60%/55%		
Twin wall 10mm	79%	35%	30%		35%	30%				25%		60%/55%		
Triple wall 8mm	76%	35%	48%		35%	30%				25%				
Triple wall 10mm	76%	35%	48%		35%	30%				25%				
Triple wall 16mm	76%	35%		48%	35%	30%								
X-Lite 16mm	60%	25%		38%	35%							30%/25%		
V-Structure 20mm	63%													
X-Lite 25mm	60%	25%	15%				10%	5%	20%			20%/16%		42%/35%
X-Lite 32mm	58%	20%	15%				10%	5%	20%			20%/16%		42%/35%
X-Lite 35mm	57%	20%	15%				10%	5%	20%			20%/16%		42%/35%
X-Lite 40mm	57%	20%	15%											

*ASTM D-1003

**Blue, Green and Solar Control sheets are produced per order.

Typical Physical Properties

Property	method*	Condition	Units	Value
Density	D-792		g/cm ³	1.2
Heat deflection temperature (HDT)	D-648	Load: 1.82 MP	°C	135
Service Temperature - Short term			°C	-50 to +120
Service Temperature - Long term			°C	-50 to +100
Coefficient of linear thermal expansion	D-696		mm/mm °C	6.5x10 ⁻⁵
Tensile strength at yield	D-638	10 mm/min	MPa	62
Elongation at break	D-638	10 mm/min	%	>90
Impact falling dart	ISO 6603/1		J	40-400
Practical thermal expansion/contraction			mm/m	3

* ASTM except where noted otherwise.

Flammability*

Method	Classification*
EN 13501	B, s1, d0
BS 476/7	Class 1
DIN 4102	B-1 (10&16mm Triple Wall)
NSP 92501	M-1, M-2
ASTM D-635	CC-1 (SUNLITE® SL)
ASTM E-84	Class A

* Classifications depend on sheet type and thickness. For more information please refer to your SUNLITE distributor.

Chemical Resistance & Compatible Sealants

SUNLITE has good resistance to many chemicals. Some chemicals may harm the SUNLITE sheets. Detailed information about these materials can be found in PALRAM's "Chemical Resistance of Polycarbonate Sheets" brochure. Please contact your PALRAM dealer when in doubt about any material or chemical.

When choosing adhesives or sealants to be used during installation of SUNLITE sheets, please consult PALRAM's brochure "Recommended Adhesives and Sealants for Polycarbonate Products", which is available on PALRAM's website (www.palram.com).

For use of any adhesive or sealant not listed in the above brochure, consult with your PALRAM dealer to get his approval. Failure to do so will void any and all warranties.

Positioning the Sheets

1. SUNLITE sheets should be installed with the rib channels sloping downwards (Figs. 1a, 1c, 2). That orientation will reduce accumulation of dirt inside the sheet and ease gravity drainage of any condensation moisture.

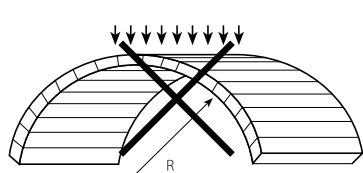

Figure 1a

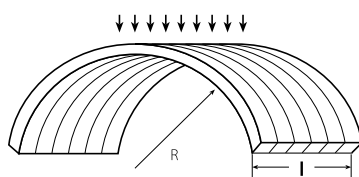

Figure 1b

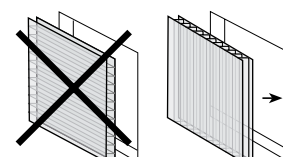

Figure 1c

2. Sheets should be installed with the adjoining edges connected by a glazing profile suited to the glazing system.

3. For sheets installed in the flat, horizontal position, (roofs, overhead skylights), a minimum slope of 5 percent is imperative, with 10 percent and above preferable. Steeper slopes offer better rainwater drainage and self-cleaning, and reduce the risk of water and dirt infiltration through the connectors and fastening screws. Steeper slopes also help to diminish the visual effect of sheet deflection caused by loading.

4. Length dimension is defined as parallel to the ribs, while width will always be perpendicular to the ribs.

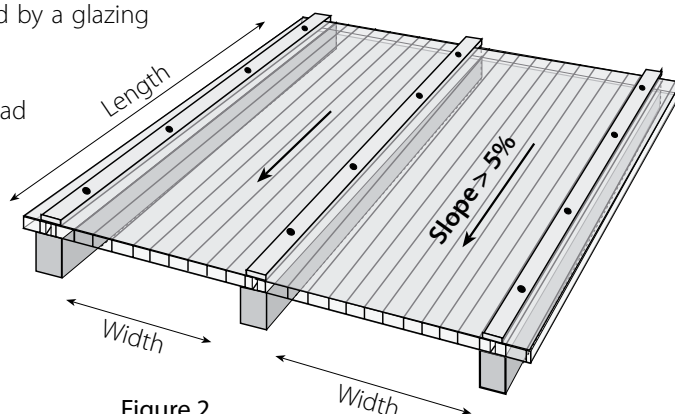
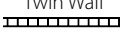
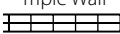
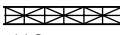
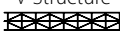

Figure 2
Flat, two-sided clamped glazing

Arching Radius

SUNLITE sheets may be cold bent or curved up to their minimum permitted radius, using polycarbonate's natural tolerance for cold forming with no need for thermal processing. Curving SUNLITE sheet beyond this minimum permitted radius induces undue stresses and strains in the glazing sheet, causing premature failure and will void the warranty.

Structure	Thickness		Minimal Cold Bending Radius		
	mm	inch	mm	feet	inch
 Twin Wall	4	5/32	700	2.30	28
	6	1/4	1,050	3.40	41
	8	5/16	1,400	4.60	55
	10	3/8	1,750	5.70	69
 Triple Wall	8	5/16	1,760	5.80	69
	10	3/8	2,200	7.20	87
	16	5/8	2,800	9.20	110
 X-Lite	16	5/8	3,000	9.80	118
	25	1	5,000	16.40	197
 V-Structure	32	1 1/4	6,400	21.00	252
	35	1 3/8	7,000	23.00	276

Wind and Snow Load Calculation

Local building codes and standards in most countries provide details for required design loads, which should be consulted before installation. The information below is provided for general reference.

Conversion of Wind Velocity Values into Wind (or Static) Pressure

Property	Units	Wind Strength Level			
		Moderate	Strong	Storm	Hurricane
Wind velocity	km/h	20	40 - 60	80 - 100	120 - 140(+)
	m/sec	6	11 - 17	22 - 28	33 - 40
Static pressure	kg/m ²	2	8 - 17	30 - 50	70 - 100(+)
	psf	0.4	2 - 4	6 - 10	14 - 20(+)

Snow Load: Snow load from accumulated snow cannot be disregarded. Both structure and glazing should be suitable for this extra weight. In snow-bound areas, SUNTUF or SunSky single wall corrugated polycarbonate glazing is often preferable for roofing purposes. Please consult with your PALRAM distributor.

Indicative snow load	per 1.0 cm (0.4 inch) of height or thickness
Fresh, fine, fluffy snow	from 0.8 to 1.9 kg/m ² (0.16-0.39 psf)
Wet, watery, compacted snow	from 2.0 to 8.0 kg/m ² (0.41-1.64 psf)

Spacing and Load Calculations for Different Methods of Installation

1. Four Sides Clamp or Frame

This method utilizes comparatively small, separate glazing elements, cut from larger sheets. SUNLITE is put inside a four-sided frame or supporting structures, and clamped on all sides. Clamping is done by plastic, wood or metal clamping profiles, with or without rubber sealing strips, and fastened by nails, screws or bolts to the supporting frame. The frame itself can be made of wood or metal, according to the design.

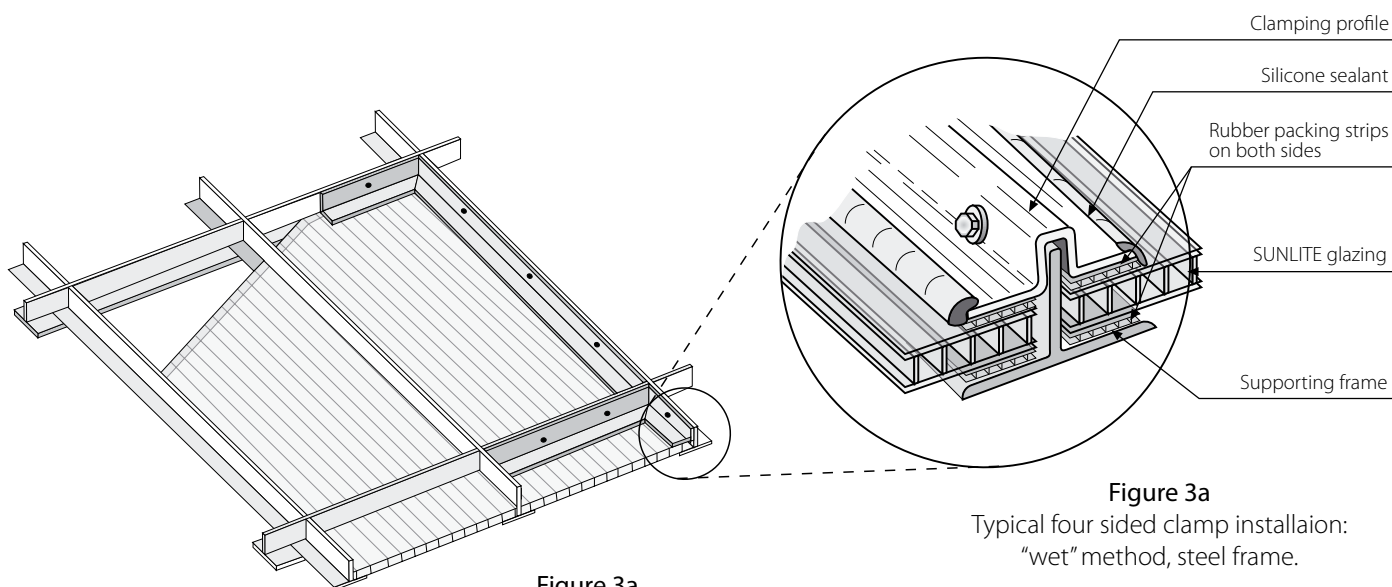

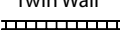
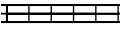

Figure 3a
Typical four sided clamp installation:
"wet" method, steel frame.

Figure 3a
Typical four sided clamp installation:
"wet" method, steel frame.

The table on top the next page presents the recommended center-to-center spans, for each type of SUNLITE sheet at various wind or snow loads.

Maximum Recommended Distances Between Centers- Shorter Spans (width)

Under different ratios and loads for four sides clamped / framed flat glazing.

Structure	Thickness	Wind/snow uniform loads		Distance between centers (shorter span) according to ratio a:b					
				Ratio 1:1		Ratio 1.5:1		Ratio > 1.5:1	
				mm	Inch	mm	Inch	mm	Inch
Twin Wall 	6	Kg/m ²	psf	mm	Inch	mm	Inch	mm	Inch
		50	10	900	36	700	28	500	20
		80	16	700	28	500	20	350	14
		100	20	500	20	400	16	-	-
	8	120	25	400	16	300	12	-	-
		50	10	1150	45	900	36	600	24
		80	16	1000	40	800	28	480	19
		100	20	900	36	650	22	450	18
	10	120	25	750	30	600	20	-	-
		50	10	1250	50	1000	40	750	30
		80	16	1200	47	900	30	550	22
		100	20	1100	43	800	24	500	20
Triple Wall 	8	120	25	950	37	700	21	450	18
		50	10	1200	47	950	38	650	26
		80	16	1050	42	750	29	510	20
		100	20	950	37	650	22	470	18
	10	120	25	900	38	650	22	480	19
		50	10	1275	51	1050	41	800	32
		80	16	1225	49	900	32	600	24
		100	20	1125	44	750	26	550	22
	16	120	25	900	38	650	22	480	19
		50	10	1500	59	1200	47	1100	43
		80	16	1300	52	1100	43	1000	41
		100	20	1200	47	1050	41	900	36
X-Lite 	16	120	25	1100	43	950	37	850	33
		50	10	1550	61	1250	49	1150	45
		80	16	1350	53	1150	45	1050	41
		100	20	1240	49	1080	42	950	37
	25	120	25	1130	44	980	38	900	35
		50	10	2100	83	1700	67	1400	55
		80	16	1950	76	1600	63	1650	53
		100	20	1800	70	1500	59	1300	51
	32	120	25	1650	65	1400	55	1250	49
		50	10	2100	83	1850	73	1500	59
		80	16	2100	83	1700	67	1400	55
		100	20	2000	78	1600	63	1350	53
35	120	25	1850	73	1500	59	1300	51	
	50	10	2100	83	1875	74	1525	60	
	80	16	2100	83	1725	68	1425	56	
	100	20	2025	79	1652	64	1375	54	
		120	25	1875	74	1525	60	1325	52

Notes:

1. SUNLITE 4mm twin-wall is not recommended for constructive applications and is therefore excluded.
2. Data in table according to load tests on typical multi-wall sheets and additional extrapolations.
3. Recommended spans are calculated on the basis of 1/20 maximum deflection (5%) of sheet's width (In this case crosswise, perpendicular to the rib channels).
4. A SUNLITE glazing sheet may withstand even higher loads without buckling, however, excessive lateral shortening, created by higher deflection, may cause the edges to slip out of their supports (pop-out).

2. Two-Sided Clamped Glazing

This is a simpler glazing system to install, requiring no mid-sheet fastening, using long glazing sheets, and held in place by two glazing profiles on both longitudinal edges. It is not as strong, and permitted width is limited (the width direction of a multi-wall sheet is more vulnerable to loads, span-wise, especially the thinner, square ribbed 6, 8 and 10 mm sheets).

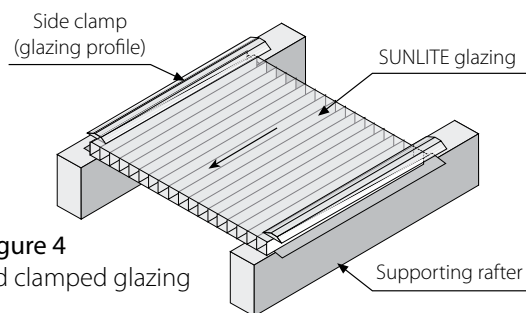

Figure 4
Flat, two-sided clamped glazing

Maximum Width of SUNLITE Sheets in Two Sides Clamped Flat Glazing

Uniform Load		Structure																			
		Twin Wall						Triple Wall						X-Lite							
Kg/m ²	psf	6		8		10		8		10		16		16		25		32		35	
		mm	Inch	mm	Inch	mm	Inch	mm	Inch	mm	Inch	mm	Inch	mm	Inch	mm	Inch	mm	Inch	mm	Inch
50	10	450	18	540	21	680	27	575	19	700	25	990	39	1100	44	1250	50	1200	48	1200	48
80	16	320	13	430	17	500	20	450	15	525	18	900	36	1050	41	1100	43	1000	38	950	38
100	20	-	-	400	16	450	18	400	14	475	17	800	32	1000	35	1050	41	950	37	875	35
120	25	-	-	-	-	400	16	-	-	425	14	700	28	975	38	1000	40	900	36	800	32

Notes:

The notes attached to the previous table (Maximum Recommended Distances) also apply here.

3. Two-Sided Clamped Arched Glazing

1. SUNLITE sheets can be curved into arches within the permitted radius (see "Arching Radius" on page 3) without damaging their mechanical performance. Moreover, internal stresses induced by curving give the sheets extra strength and rigidity in both directions, like pre-stressed concrete elements.

2. Rigidity and support spans increase as the curve radius is reduced (down to the minimal permitted radius). Shallow curving should be considered to be similar to flat panels, while a deep curve significantly adds to the bridging ability.

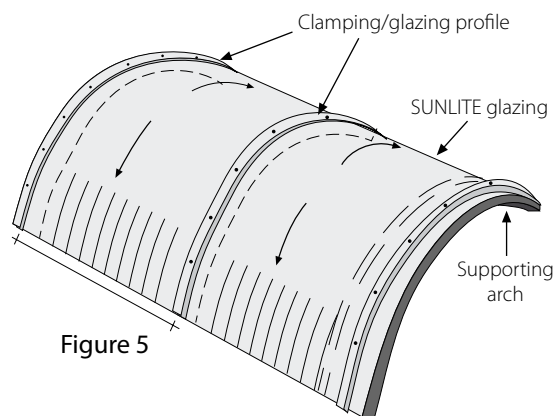





Figure 5

The table in the next page shows the growing rigidity from the curving of SUNLITE, at various uniform loads.

Maximum Recommended Spans between Arched Supports

According to radius of curve and load for two sides clamped glazing.

Structure	Thickness	Sheet curvature radius		Recommended (center-to-center) Distance between Supporting arches according to wind/Snow loads below															
				50 Kg/m ²		10 psf		80 Kg/m ²		16 psf		100 Kg/m ²		20 psf		120 Kg/m ²		24.6 psf	
				mm	Inch	mm	Inch	mm	Inch	mm	Inch	mm	Inch	mm	Inch	mm	Inch	mm	Inch
Twin Wall 	6	1050	41	2000	79	1730	68	1420	56	1020	40								
		1500	59	1470	58	1090	43	890	35	660	26								
		1800	71	1140	45	860	34	690	27	580	23								
		2200	88	810	32	690	27	-	-	-	-								
		2800	110	500	20	350	14	-	-	-	-								
		4000	158	500	20	350	14	-	-	-	-								
	8	1400	55	1650	65	1450	57	1320	52	1170	46								
		1800	71	1420	56	1270	50	1070	42	890	35								
		2200	88	1090	43	890	35	710	28	600	24								
		2800	110	840	33	620	19	450	18	-	-								
		4000	158	600	24	500	19	-	-	-	-								
		6000	236	570	23	480	19	-	-	-	-								
	10	1750	69	1630	68	1420	56	1170	46	1020	40								
		2200	88	1320	52	960	38	810	32	660	26								
		2800	110	890	35	650	26	600	24	550	22								
		4000	158	750	29	550	22	500	20	450	18								
		6000	236	700	27	520	21	500	20	420	18								
	Triple Wall 	8	1760	70	1320	52	1170	46	980	39	750	30							
2200			87	1025	41	780	31	580	23	520	21								
2800			110	750	30	570	23	400	16	-	-								
4000			158	500	20	450	18	-	-	-	-								
6000			236	480	19	400	16	-	-	-	-								
10		2200	88	1220	48	880	35	720	29	580	23								
		2800	110	780	31	580	23	500	20	450	18								
		4000	158	620	25	500	20	450	18	400	16								
		6000	236	550	22	450	18	400	16	-	-								
		2800	118	1850	73	1650	65	1450	57	1200	48								
16	4000	158	1450	57	1220	48	940	37	850	34									
	6000	236	1050	42	1000	40	850	34	800	32									
	3000	120	1750	69	1600	63	1500	59	1400	55									
X-Lite 	16	5000	200	1350	53	1200	47	1100	43	1000	39								
		5000	197	1650	64	1450	57	1400	55	1350	53								
	25	6000	236	1550	61	1350	53	1300	51	1250	49								
		6400	252	1650	64	1550	61	1350	53	1300	51								
	32	8000	315	1550	61	1450	57	1250	49	1200	47								
		7000	276	1650	65	1550	61	1350	53	1300	51								
	35	8200	322	1550	61	1450	57	1250	49	1200	47								

Notes:

1. A hyphen sign in the table (-) means that the sheet cannot be used at the relevant range.
2. Generally a span of less than 600 mm (24 in.) is impractical for this installation configuration.
3. The lowest radius dimension (first in the column) appearing in the table, for each type of sheet, is the minimum permitted cold bending radius of that specific type.

4. "Roofing & Cladding" Installation Method

This is a simpler, more practical method, resembling the one used for single-wall, corrugated plastic (or metal) sheets. It employs longer strips, with wider dimension. Length is as long as possible without excess deformation by thermal expansion. SUNLITE sheets are laid on top of the purlins, with rib channels directed down the slope, perpendicular to the purlins. Span between purlins is determined by the load and deflection characteristics of the specific SUNLITE sheet.

1. The sheets are connected to each other by long connecting elements.
2. The wide variety of these connection methods falls into two main categories: "wet" or "dry" installation systems. The connecting elements (made of aluminum, sheet metal or plastic- rigid PVC or polycarbonate) are designed as connectors, not as load supporting members. They connect the sheets to each other, achieving one unified watertight exterior shell. Additional strength and rigidity achieved through them is an added bonus.

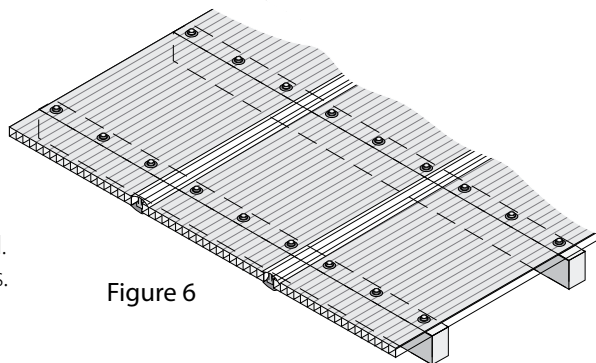

Figure 6

Basic inverted "H" polycarbonate connecting profile

An old and simple form enabling a lengthwise (side by side) connection between twin/multi-wall sheets. It is sometime offered with a specific size profile for each sheet thickness, or in versatile, more flexible design enabling the use of one profile with 2 consecutive thicknesses (4-6 & 8-10 "H" profiles). This connecting method is practically inappropriate for the thicker SUNLITE panels.

1. "Dry" method: The edges on both sides are inserted into the profile, holding the sheets by "dry" mechanical friction, with the sheets on both sides fastened to the structure, along the purlins, by fixing screws, about 500-600 mm (20-24 inches) apart.



Figure 7

Basic, inverted H polycarbonate connecting profile

2. "Wet" method: both the profile channels are half-filled with silicone, which acts, after installation and curing, both as sealer and adhesive. It may offer better weatherproofing at shallower slopes, than the "dry" system, but is very difficult to install properly and cleanly (Figure 7).

Notes:

1. The connector itself is not fixed to the purlins.
2. Both systems are basic and disclose several shortcomings: difficult and bothersome installation, plain looks, weak and imperfect connection and sealing. Installation may prove to be lengthy and messy for inexperienced hands. They are, however, considered the cheapest.

Two-part polycarbonate connecting profile, which is made of:

1. A lower base profile, usually the more rigid of the two, on which the edges of the adjoining sheets are placed. Usually the base profile is fastened to the purlins by screws through the middle, with both edges free, letting the sheets slide easily due to the thermal expansion and contraction process.
2. The upper part, usually more flexible than the base, clips on the base profile by hand pressure, holding both sides of the adjoining sheets in place by mechanical pressure. This type is easier to install, more reliable in holding the sheets and sealing the connection. It is used, mostly, in "dry" installation, but could be assisted by silicone on the upper and lower profile. "Wet" installation like this is difficult to keep clean during installation and with long sheets may lose its effectiveness due to excessive expansion.

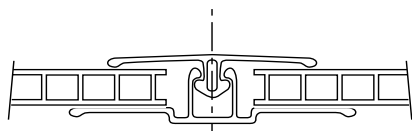

Figure 8a

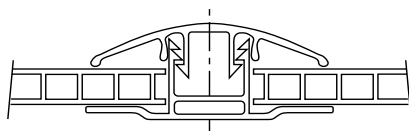

Figure 8b

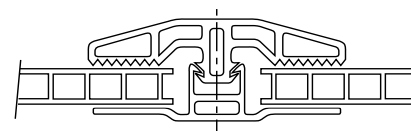

Figure 8c

Figure 8

Drawing of typical two-part polycarbonate connecting profiles currently used

Combination of metal and plastic two-part connecting profile

offers added strength and rigidity. The lower part of the profile is made of metal- (mostly aluminum), and the upper part is made of plastic (rigid PVC or polycarbonate), clipped on top of the metal profile, pressing on the edges of the two adjoining sheets.

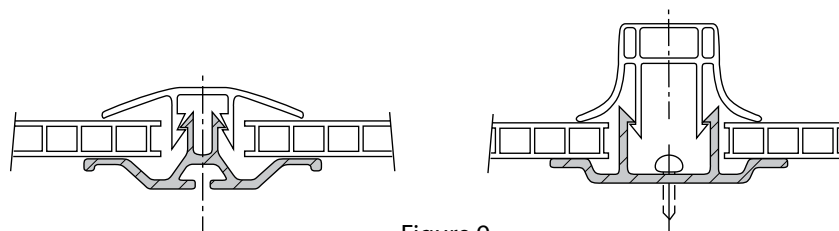

Figure 9

Description of Typical Two-Part Plastic and Metal Connecting Profiles Currently Used

Wood connecting profiles

developed from wooden window frames, support the installed SUNLITE sheets. They are usually used together with the “wet” system, with rubber packing strips and silicone sealant. Lengths are generally limited by the nature of wood. If long, laminated wooden rafters are used, they usually come with one or more of the other connecting solutions below.

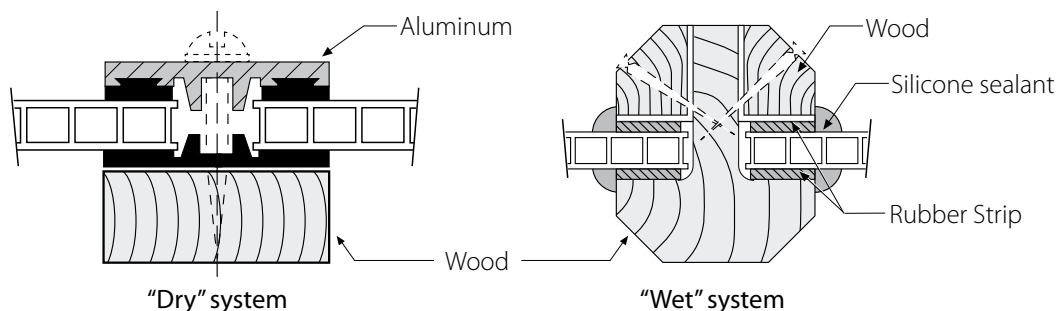

Figure 10

Description of Typical Two-Part Wood Connecting Profiles Currently used in the Market

Metal connecting profiles

comprise the largest group of connecting profiles. They come in wide variety of designs, are made from aluminum or steel, in “dry” or “wet” systems, and in plain or sophisticated detailing and finish. Some profiles are equipped with built-in drains, EPDM rubber weather strips, concealed fixing screws, and high-end finish, for more luxurious structures.

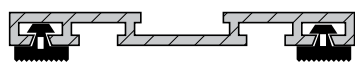

Figure 11a

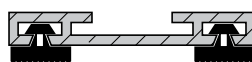

Figure 11b

Figure 10

Typical Two-Part Metal System Connecting Profiles Currently Used

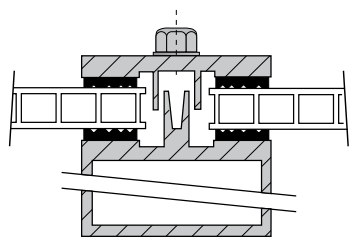

Figure 11c

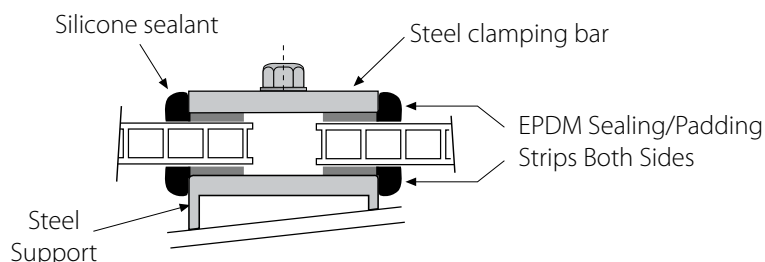

Figure 11d

Mid-Sheet Fasteners

(Not recommended for D.I.Y Applications)

1. A wider sheet has to be fastened to the supporting structure by additional fastening along its width, as the connectors on both longitudinal sides are not enough to hold the sheet down, against the uplift force it has to withstand.

2. Fastening is usually done by screws, inserted along the supporting internal purlins, spaced about 500mm (20in.) apart.

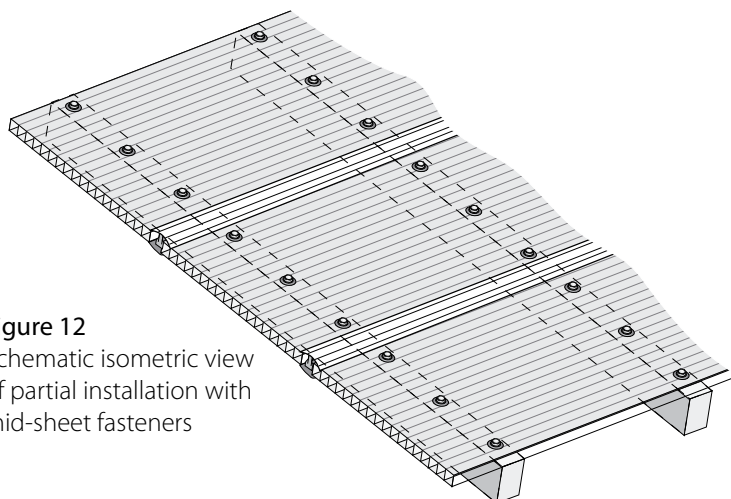

Figure 12
Schematic isometric view of partial installation with mid-sheet fasteners

3. Along the edge purlin, the fastening screws should be inserted about 300 mm (12 in.) apart.

4. A hole must be pre-drilled into each screw location. The diameter of that hole should be 2 mm larger than that of the screw, to allow for thermal expansion movements. In case of dark colored sheets predrill even larger holes, and use wider fastener washers.

5. An electric screwdriver with an adjustable clutch should be used to tighten the screws. Avoid excess overtightening, which might induce undue internal stresses, causing premature failure and buckling of the sheet. Pay attention to insert the screws perpendicular to the material face, as inclined insertion could damage the sheet and/or result in leaks.

Figure 13
Typical installation screws and obligatory washers

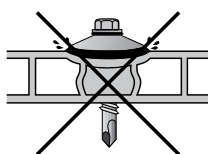

Figure 13a
Incorrect - Overtightening

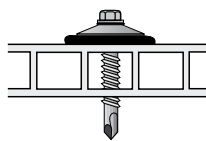

Figure 13b
Correct

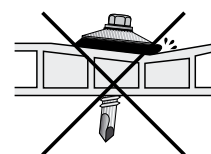

Figure 13c
Incorrect - Non-perpendicular drilling and insertion



Figure 13a
Self-tapping screw



Figure 13b
Self-drilling screw



Figure 13b
Wood screw

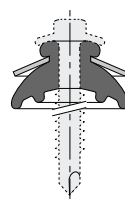

Figure 13g
25mm special washer/gasket

6. Use of self-tapping or self-drilling screws is recommended. In case of wooden structures, suitable wood-screws should be used. All the screws should be corrosion resistant, with at least heavy-duty hot-dipped galvanized finish, or stainless steel (if used in an extremely corrosive environment). The screws should be 6 mm (1/4 in.) diameter, with length according to sheet thickness, type of washer and type of supporting structure.

7. Each screw should be fitted with a conical corrosion resistant steel washer, with specifications as the screws above or of aluminum, at least 1 mm (0.04 in.) thick, 25 mm (1 in.) diameter, with a Specially Shaped integral rubber gasket, EPDM (see PALRAM special washer/gasket fig. 13g). The screw should be tightened carefully, with no distortion of the washer and rubber gasket, or the flat face of the sheet PALRAM will supply the suitable fasteners and washers with the SUNLITE sheets unless required otherwise.

8. Screw buttons: Improved performance can be obtained by replacing the washers with special plastic screw buttons, fitted with a suitable rubber gasket, with or without a closing cap. They fit the thickness of each type of sheet (6, 8, 10, 16 mm, and possibly 25 mm), differing by sleeve length. Their advantage: the sleeve prevents excessive tightening and local squashing around the screw, and is softer on the sheet, reducing risk of tear or shear around the screw's stem. They also offer a seal between the fastener hole and the open channels of the sheet, preventing possible infiltration of water and dirt into the internal space of the sheet. Screw buttons work with the same screws mentioned above (6 mm, 1/4 in.), maybe a little longer due to the higher thickness of the button.

PALRAM recommends perforating SUNLITE for fastening as little as possible, and prefers the use of clamped edge installation. PALRAM recommends that the use of fastening screws in a glazing system, even with plastic buttons, should be limited to economical, price conscious projects only. Two or four-sided clamped glazing is a preferred choice.

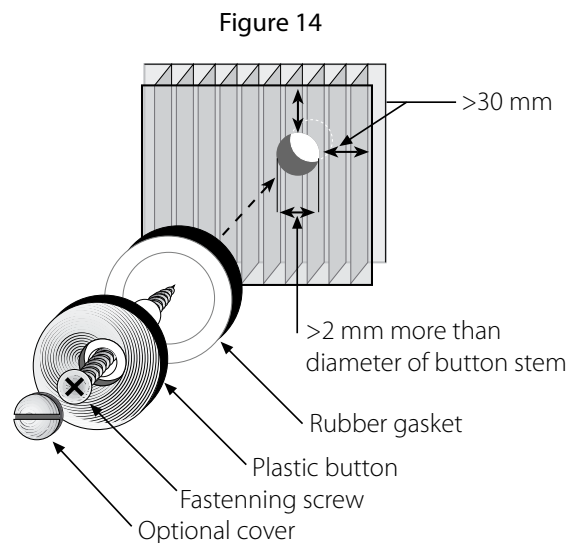

Design spans between Supporting Purlins

According to Designated Loads for the Roofing and Cladding Method

Max. Recommended Spans between Support Purlins - Flat / Slightly Curved Roofing/Glazing

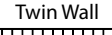
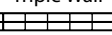
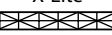
Structure	Thickness	Distance (center-to-center) between supporting purlins - according to wind/Snow loads below							
		50 Kg/m ²	10 psf	80 Kg/m ²	16 psf	100 Kg/m ²	20 psf	120 Kg/m ²	25 psf
	mm	mm	Inch	mm	Inch	mm	Inch	mm	Inch
Twin Wall 	6	900	36	800	32	650	26	500	20
	8	1150	46	1000	40	850	34	650	26
	10	1250	50	1150	46	1050	42	900	36
Triple Wall 	8	1120	44	970	38	820	32	620	25
	10	1220	48	1125	45	1020	41	870	35
	16	1600	64	1450	58	1250	50	1130	45
X-Lite 	16	1650	65	1500	59	1300	51	1180	46
	25	1850	74	1700	68	1550	62	1425	56
	32	2050	82	1900	76	1750	69	1600	63
	35	2075	82	1925	76	1775	70	1625	64



Notes:

- Span calculation is based on general professional know-how, previous experience & specialized expertise with this type of products.
- Spans depicted are drawn from loading tests and extrapolations based on L/20 deflection (5%) at the specific span and load using continuous multi-span supports. The values refer to mid-spans. Edge-spans (lower & upper ends) should be approx. 20% smaller.
- SUNLITE panels can withstand higher loads and/or wider spans without failure. However the involved deflections will exceed L/10 (10%) of the span, which is unacceptable in most cases.

Curving SUNLITE sheets gives them higher strength and rigidity, as in the case of two-sides clamping described in the next page.

Maximum Recommended Distances between Support Purlins

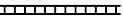
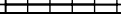
for Curved Roofing/Cladding, According to Curvature Radius and Load.

Structure	Thickness	Sheet curvature radius		Recommended (center-to-center) Distance between Supporting arches according to wind/Snow loads below														
				50 Kg/m ²		10 psf		80 Kg/m ²		16 psf		100 Kg/m ²		20 psf		120 Kg/m ²		24.6 psf
	mm	mm	Inch	mm	Inch	mm	Inch	mm	Inch	mm	Inch	mm	Inch	mm	Inch	mm	Inch	
Twin Wall 	6	1050	41	2000	79	1730	68	1420	56	1020	40							
		1500	60	1570	62	1570	62	1200	48	1200	48							
		1800	72	1420	56	1420	56	1150	46	1150	46							
		2200	86	1380	55	1380	55	1150	46	1150	46							
		2800	110	1260	50	1260	50	1100	44	1100	44							
		4000	158	1150	46	900	36	850	34	780	31							
		6000	236	900	36	800	32	650	26	500	20							
	8	1400	55	1570	62	1570	62	1570	62	1570	62							
		1800	72	1880	74	1420	56	1420	56	1420	56							
		2200	86	1730	68	1380	55	1380	55	1380	55							
		2800	110	1470	58	1470	58	1250	50	1100	43							
		4000	158	1250	50	1150	46	1050	40	900	32							
		6000	236	1150	46	1000	40	850	34	650	26							
		10	1750	69	1885	74	1885	74	1885	74	1885	74						
	2200		88	1725	68	1725	68	1725	68	1725	68							
	2800		110	1470	58	1470	58	1250	50	1100	43							
	4000		158	1250	50	1150	46	1050	40	900	32							
	6000		236	1150	46	1000	40	850	34	650	26							
	8	1760	70	1420	55	1420	55	1380	53	1380	56							
		2200	86	1380	53	1380	53	1380	53	1250	49							
		2800	110	1380	53	1380	53	1250	49	1070	42							
		4000	158	1150	46	1050	42	1050	42	750	30							
		6000	236	1100	44	960	38	825	33	625	25							
		1800	72	1885	74	1885	74	1885	74	1885	74							
2200		86	1725	68	1725	68	1725	68	1725	68								
Triple Wall 	10	2800	110	1750	69	1750	69	1750	69	1465	58							
	4600	158	1570	62	1570	62	1260	50	1260	50								
	6000	236	1260	50	1180	47	1075	42	900	36								
	16	2800	110	2100	83	2050	81	2000	79	1950	77							
	4000	158	1750	69	1700	67	1650	65	1600	63								
16	6000	236	1600	63	1400	56	1250	50	1150	46								
	3000	118	2125	84	2075	81	2025	79	1975	77								
	4000	158	1800	71	1750	69	1700	67	1650	65								
	6000	236	1600	63	1400	56	1250	50	1150	46								
	25	5000	197	1300	90	2050	80	1770	70	1500	59							
X-Lite 	32	6000	237	2100	69	1850	73	1570	62	1300	51							
	6400	252	2200	86	2050	80	1770	67	1500	59								
	8000	315	2100	82	1950	76	1670	65	1400	55								
35	7000	276	2200	86	2050	80	1770	67	1500	59								
	82000	323	2100	82	1950	76	1670	65	1400	55								

Notes:

- SUNLITE 4mm twin-wall is not recommended for constructive applications and is therefore excluded.
- The specified spans are based on L/20 deflection (5%) at the specific span and load, using continuous multi-span supports. The values refer to mid-spans. Edge-spans (lower & upper ends) should be approx. 15-20% smaller.
- Spans depicted in all but the largest radii (6.00-8.00 m) derive from division of a full 180° barrel vault of the specific radius into equal size sectors. (For instance - an arch of 1.10m radius is divided into 2 equal parts of 1.73 m length. An arch of 1.50 m radius is divided into 3 parts each 1.57 m long, and so on.)
- Curved SUNLITE is more rigid and allows for a much wider span than in flat installation, especially in smaller radii. Rigidity and strength are reduced as the radius is increased (for same type of panel). A lightly curved panel behaves almost the same as a flat one.

Figure 15
Schematic description of standard curved roofing in a vault

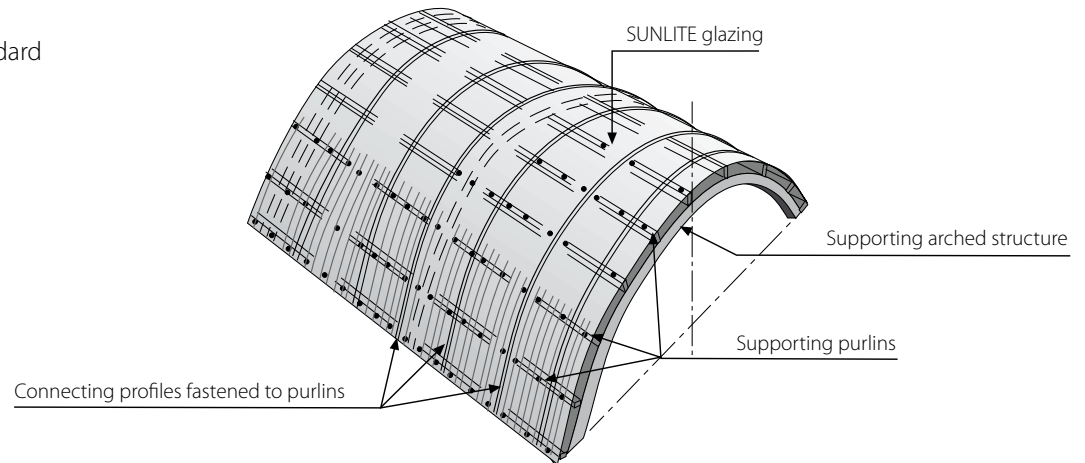

General Notes for Structural Design

1. The recommended support spacing, as specified in the load/span tables, should not supersede the requirements of local structural and construction codes. The final values are to be dictated by actual conditions on site and engineering design.
2. The end spans, i.e. the distance between the edge support (or purlin) and the first internal purlin should be up to 80 percent of the commonly recommended span for this load and type of sheet, or the value dictated by the design engineer.

Positioning of Clamping Profiles and Fastener Location

1. Using the four-sided clamped glazing system, the support bars should be underneath (or inside), and the glazing clamps on top (or outside). SUNLITE must be installed with the clamping profiles covering all four edges of the sheet. (These are load-bearing elements, which connect the glazing to the supporting structure, transferring loads from the glazing to it.)
2. Using the two-sided clamped glazing system, the support bars (and glazing clamps) should be installed covering the two longitudinal edges of the sheet, parallel to the rib channels. (Again, these are load-bearing elements, connecting the glazing to the supporting structure, transferring loads from the glazing to it.)
3. Using the roofing/cladding method, glazing connectors (of any version) should be installed on both long sides of each sheet (parallel to the rib channels). Their main duty is connecting adjoining sheets. They may assist transferring loads to the structure, but here the fastening screws transfer most of the load to the supporting structure (the purlins). The screws, with their metal washer and rubber gaskets, should be inserted along the length of the supporting purlins, about 500-600 mm (20-24 in.) apart and 300-400 mm (12-16 in.) at the edge purlin. When using metal glazing connectors, they are positively fastened to the purlins.

When using polycarbonate connecting-profiles, some types are fastened and others do not. In that case, the fastening screws will be placed on both sides of the connector, about 200-250 mm (8-10 in.) on each side.

Preparation for Glazing

Determination of Rabbet Depth and Thermal Expansion Allowance

These parameters depend on the SUNLITE sheet dimension, and relate to the four sides of the sheet (four-sides clamping system), or to the two edges parallel to the rib channels (two-sides clamping system).

1. Allowance for expansion

SUNLITE expands about 3mm for every meter (1/8 in. per 3 1/3 ft.) of length (or width) for a service temperature range of about 50°C (90°F), the practical working range in most cases. For a sheet of 1.00 m (or 40 in.) wide, 1.50m (60 in.) long, a net allowance of 3 mm (width) and 5mm (length) should in theory suffice. We recommend doubling this allowance for practical reasons. Allowance should be divided between both sides of the sheet. When the ends of panels are protected by a recessed 'U' channel, allow suitable internal space for thermal expansion.

2. Edge Engagement: (the overlap of the glazing over its frame).

3. Rabbet Depth: (expansion allowance + edge engagement). PALRAM recommends a rabbet depth of at least 20 mm (0.8 in.) for widths up to 1.0 m (40 in.) and a depth of 25-30 mm (1.0 - 1.2 in.) for wider spans.

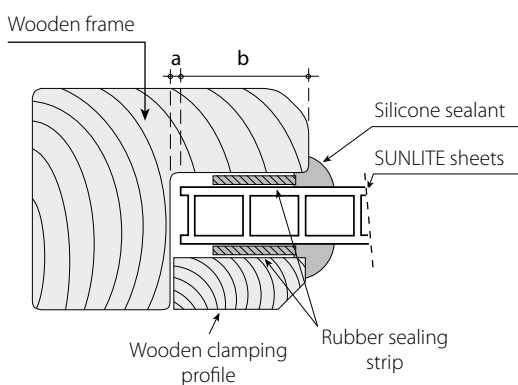

Figure 16b
"Wet" Glazing

Legend
a = Expansion allowance
b = Edge Engagement depth
c = Rabbet depth: a+b

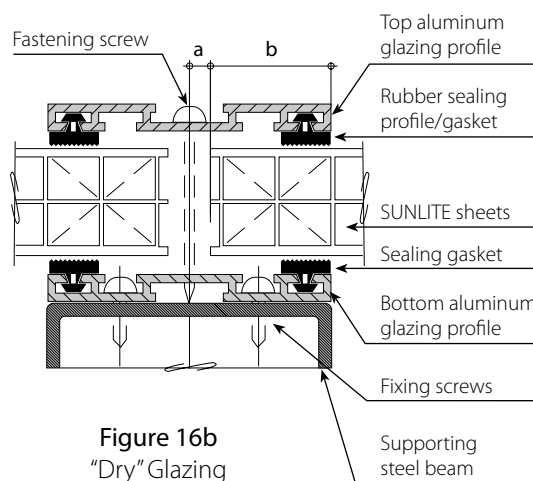
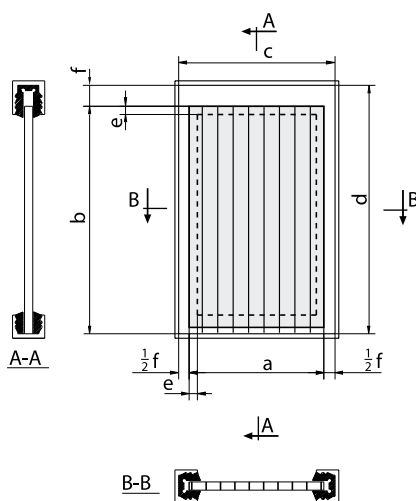

Figure 16b
"Dry" Glazing

Figure 16c

Schematic Sketch of Rabbet depth and Expansion Allowance ("wet" and "dry" methods)

- a. Sheet width
- b. Sheet length
- c. Sash (frame) width
- d. Sash length
- e. Edge Engagement depth (overlap)
- f. Thermal expansion allowance
- g. Rabbet Depth e + f



Preparations Prior to Installation

1. Ensure smaller thermal expansions by installing sheets - especially colored sheets - at ambient temperatures of 10-25deg. °C (50-77 deg. °F). It is generally recommended to avoid installing sheets at colder or hotter temperatures.
2. Peel off the protective film at both open ends of the sheet (the width sides) to about 80-100 mm (3.5-4 in.) from the edges of the sheet, to enable taping of the aluminum sealing tape. If a factory installed temporary seal is taped over the open ends, it should be removed prior to the installation of the aluminum tape. Tape the sealing tape straight along the open-end side, so it will cling well and evenly to both sides of the sheet, making sure that all the open ends of the rib channels are properly sealed.
3. Peel off the masking along the edges of length sides at both sides of the sheet, for about 80-100 mm (3.5-4 in.) from the edges, preparing the sheet for the insertion into the connecting profiles or the glazing frame.
4. Remove the underside masking just prior to the actual installation on the roof. Premature removal of protective film may result in damage to the sheet during handling.
5. Remove the upside, exterior protective film as soon as the installation of the whole glazed area is completed, or very short time afterwards. Failing to do so would expose the protective film to direct sunlight that may fuse it to the sheet's face. This will result in difficulty to remove the protective film due to deterioration of the film, and ultimately void the warranty.



Figure 17a

Partial or Complete
Removal of Protective Film
Prior and after Installation

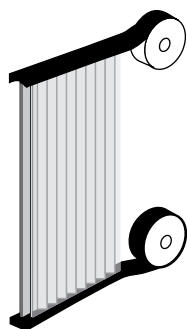

Figure 17b

Installation of Sealing Tape
on Open Ends of Sheet

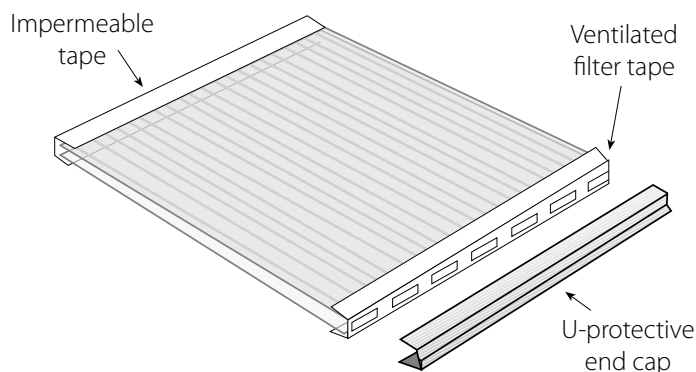

Figure 17c

Installation of Impermeable Tape at Top of the Sheet and
Installation of Ventilated Tape at the Bottom of the Sheet

6. Ensure the use of the proper type of sealing tape according to the application used, verifying that the prepared sheets are mounted correctly.

Please note: In case of curved installation, where both open ends are situated at the bottom - apply the ventilated tape on both ends. Take care to protect the sealing tapes at both ends from mechanical damage by covering the edges with aluminium U-profiles, or cover them with polycarbonate U-shaped profiles (Fig-17c).

Glazing Profiles & Fastening Screws

Type of glazing/clamping profile used in the installation of SUNLITE sheets, differs according to the glazing system chosen:

1. Framing profiles are similar in concept and detail to those used in fixed glass windows, curtain walls and skylights, made of wood, steel or aluminum, but wider, allowing for the larger Edge Engagement depth required for SUNLITE. The frames are prepared in advance, and glazing is done after they are all in place, along with completion of the other finishing jobs. (See Figures 3a, 3b).
2. Two and four-sided clamped glazing employ practically the same profiles used for framing, as used in curtain walls and skylights. Almost all are prepared prior to the glazing work, and just the clamps, the rubber packing profiles (and silicone sealant in "wet" glazing) are installed along with or after the glazing is in place.
3. The roofing and cladding glazing installation method installs SUNLITE over the supporting skeleton, rafters and purlins. The glazing profiles, which are usually flatter by design, consist of top and bottom parts, made of polycarbonate, rigid PVC or a combination (a bottom aluminum profile and top profile made of polycarbonate, or rigid PVC). SUNLITE sheets and their connecting profiles (also acting as glazing profiles) are installed together, advancing step by step. Most profiles are flexible enough to be easily shaped into curves by hand, when installed over curved structures, enabling inexpensive implementation of curved glazing.

Handling and Storage

1. SUNLITE sheets should be transported and stored horizontally, on a flat, sturdy pallet whose dimensions are equal to or larger than the sheets themselves. The sheets must be secured and fastened to the pallet during transportation and handling on site. It is possible to stack the sheets with the longer sheets at the bottom and the shorter on top, leaving no unsupported overhang.

2. While moving a pallet with a forklift, always use forks as long as the sheets' width. Shorter forks on a wider pallet may cause damage to the sheets.

3. SUNLITE sheets leave the factory in packages, wrapped in white, watertight polyethylene. The wrapping should be taken off as close to the actual time of installation as possible. Storage of the sheets should be in a covered, dry, ventilated place, away from direct sunlight and rain.

4. Avoid leaving the sheet pallet in the rain, even if still wrapped, for extended periods, as water may condense inside the hollow core. Extended exposure to direct sunlight may cause heat buildup, softening the protective film, fusing it to the sheet face, making removal difficult or impossible.

5. Avoid leaving the sheets stored unwrapped, with their ends open, for more than a few days, as dust may collect inside the hollows.

6. Important! Never cover the pallet with, or place on the pallet, materials that collect heat or are good heat conductors (e.g. dark objects, metal profiles or pipes, steel sheets etc.) They may collect and deliver excess heat, and damage the sheets.

7. When necessary to store the pallet in the open, cover it with a white opaque polyethylene sheet, cardboard, or any other insulating material, taking care to cover the pallet completely.

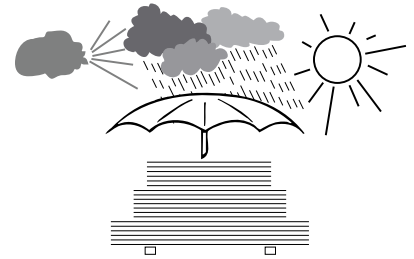

Figure 18

Cutting

1. A. SUNLITE sheets can be cut with standard wood or metal workshop equipment. Saw blades designed especially for plastic yield best results. A circular saw (fixed or portable, with small teeth suited for hardwood), rotating at high speed, band saw or a jigsaw (best for short, complex cuts) can all be used, taking care to advance the blade slowly. A hand and hacksaw may also be used for local cutting.

2. Always support the sheet in the vicinity of the cut and clean (with compressed air and/or by a vacuum cleaner) the dust and debris generated by the cutting. Running clean compressed air through the hollow channels, blowing away sawdust and shavings inside is a good practice.

3. Sheets of low and intermediate thickness, with modest dimensions, can be cut (taking the appropriate precautions) with a short, thin, sharp blade. A special cutting-wire hand tool may also be used, to make lengthwise cuts.

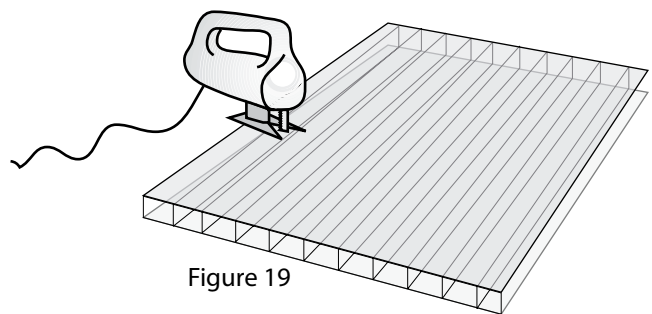
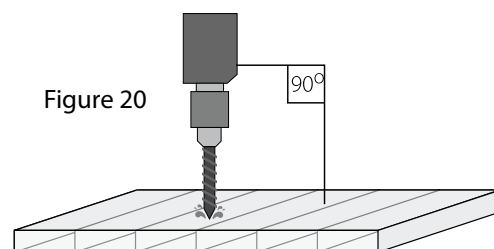

Figure 19

Drilling

1. Drilling can be carried out with drill bits intended for metal. When pre-drilling for a fastening screw, the hole's diameter should be 2 mm larger than that of the screw used. As when cutting, always support the sheet in the vicinity of the place being drilled, and clean away the sawdust and shavings, both on and inside the sheet.
2. Special attention must be given to drill all the required holes perpendicular to the face of the sheet.
3. Though drilling the sheet for fastening is a common way of installation, it is recommended to be used mostly in plain, economy-oriented projects, and used sparingly elsewhere.



Sealing and Bonding

1. **Silicone Sealant:** PALRAM strongly recommends using Dow Corning 3793 (white) or Novasil S-64 from Otto Chemie (white or translucent).
2. **Sealant and Weather Strips:** Applied in “wet” or “dry” systems.
The “**Wet**” system can use IDL 311 L Butyl rubber double-sided sticky tape by Sellotape, or simple neoprene or EPDM rubber strips, combined with the silicone sealant above.
The “**Dry**” system uses neoprene or EPDM rubber packing strips (in simpler framing system), or profiled neoprene or EPDM rubber strips inserted into grooves in the metal connecting/framing profiles. Mechanical pressure of the clamping profile on the rubber gasket achieves the sealing, like in glass systems.
3. **Sealing the Sheets** is done by aluminum impermeable, or ventilated filter sticky tapes, as described in the paragraph “Pre-preparation of the sheet” above. Such specialty tapes can be obtained from the leading tape manufacturers, or through PALRAM dealers (See figures 17b, 17c).

For alternative materials, please refer to our “**Recommended Adhesives and Sealants Polycarbonate Products**” technical information leaflet, or consult with your PALRAM distributor.

Accessories

PALRAM invests ceaseless efforts to create a complementary of accessories for the SUNLITE range of products, easing use, avoiding runaround trying to find suitable solutions for proper installation. SUNLITE can now offer suitable corrosion resistant fasteners, special washer/gasket combos and compatible sealing & bonding silicones. Immediately in line, or shortly, are basic polycarbonate “H” connectors and “U” end-caps, along with impermeable and ventilated aluminum sealing tape for end closure. Various specialized aluminum glazing profile, EPDM rubber sealing strips and gaskets will follow in the near future.

Please consult your local SUNLITE distributor for details.

Different aluminum or steel glazing profiles, structural elements, sealing materials and other components required for the completion of varied projects appear, in concept, in the sketches in this manual. Such products & materials are usually available through professional suppliers of metals and glazing accessories. Other designated elements like gutters, closures, ridge caps, trimming and flashing, etc. are to be specially fabricated according to specific design.

General Recommendations for Working with SUNLITE Sheets

Cleaning

1. Keeping SUNLITE clean will yield the best long-term results. Self-cleaning by rain is usually sufficient. Local small areas may be washed using diluted mild household detergents. Make sure the detergent contains no abrasives or solvents. Pre-wash with warm water, then wash the stained area with a soft sponge or brush, preferably with hot water, until the stain disappears. Rinse with water and dry with a soft cloth.

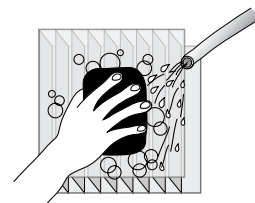

Figure 21

2. Heavy oil or tar stains can be removed with an isopropyl alcohol watery solution. Rub the area gently with a soft rag. Follow with the treatment depicted above, rinsing with a lot of water.

3. Avoid dry cleaning, as the sand and dust particles clinging to the exterior of the glazing may scratch the surface.

4. Large areas may be professionally washed by high-pressure water jet, possibly adding a mild compatible detergent, and/or a steam jet.

5. Avoid the repeated sliding of sheets over each other, even when still protected by the masking film. This action generates electrostatic charge in the sheet, attracting dirt and dust and hindering cleaning.

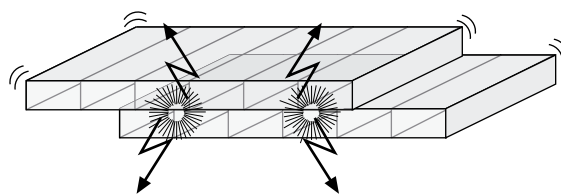

Figure 22

Safety Measures During Installation and Maintenance

1. When installing SUNLITE or doing maintenance work, always consider the sheet to be unfit to support a person's weight. Always use stepping ladders or crawling boards, supported by the roof structural elements, when working on a glazed roof of any kind.

2. Never step on SUNLITE sheet between the purlins or in the middle of a framed glazing! In emergency, step only on the lines of purlins or of structural framing.

3. Never leave the glazing sheets unattended on the roof or at the glazing area, until all the required fastening clamps or screws are secured properly. Throughout the installation process, always ensure that the sheets ready for installation are temporarily secured against sudden wind gusts.

Figure 22



Warning!

Do not step directly on the sheets between the purlins!

Inasmuch as PALRAM Industries has no control over the use to which others may put the material, it does not guarantee that the same results as those described herein will be obtained. Each user of the material should make his own tests to determine the material's suitability for his own particular use. Statements concerning possible or suggested uses of the materials described herein are not to be construed as constituting a license under any PALRAM Industries patent covering such use or as recommendations for use of such materials in the infringement of any patent. PALRAM Industries or its distributors cannot be held responsible for any losses incurred through incorrect installation of the material. In accordance with our company policy of continual product development you are advised to check with your local PALRAM Industries supplier to ensure that you have obtained the most up to date information

For more information please visit www.palram.com



PALRAM Industries Ltd.

PALRAM Israel Ltd.

Tel ▶ (972) 4 8459 900

Fax ▶ (972) 4 8459 980

E-mail ▶ palram@palram.com

Web ▶ www.palram.co.il

PALRAM Americas Inc.

Tel ▶ 610 285 9918

Fax ▶ 610 285 9928

E-mail ▶ palramamericas@palram.com

Web ▶ www.palramamericas.com

PALRAM Europe Ltd.

Tel ▶ (44) 1302 380776

Fax ▶ (44) 1302 380788

E-mail ▶ sales.europe@palram.com

Web ▶ www.palram.com

